

# Replacement Front End for FT290 Mk1 SLNA145sb

a product produced by Mutek (1983 onwards)

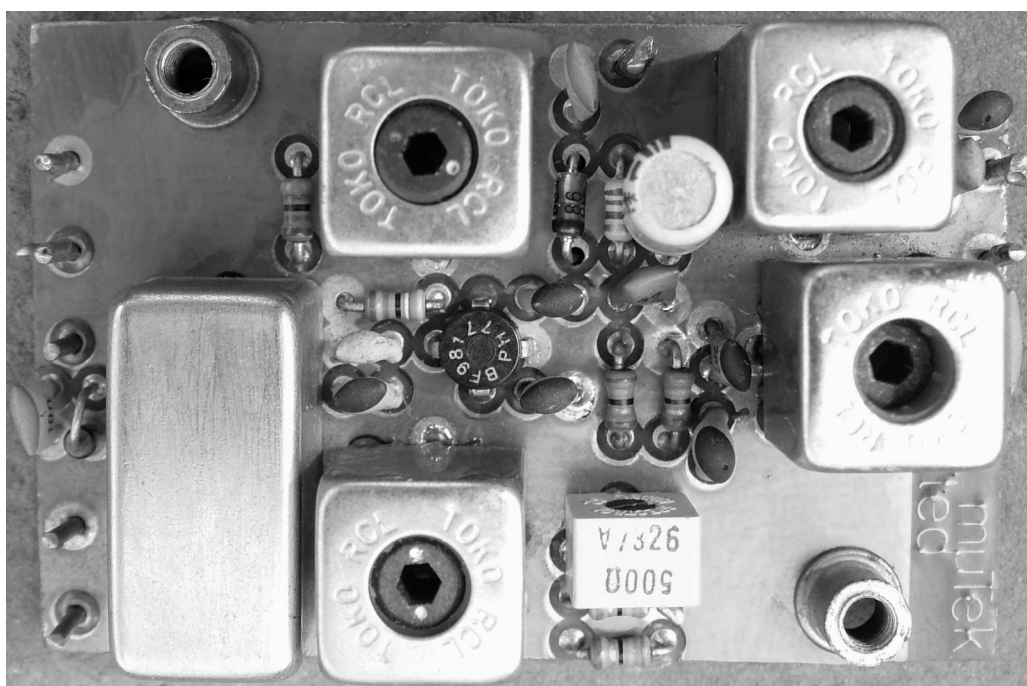

---

Manual compiled by Clive Smith, GM4FZH for general circulation

## Table of Contents

Compilers Note.....	3
Specification.....	4
Kit List.....	4
History of the PCB.....	4
Introduction.....	5
Circuit Description.....	5
Figure 1: Circuit Diagram.....	6
Table 1: Component Listing.....	6
Figure 2; Component Layout.....	7
Installation Notes.....	7
Detailed Installation.....	7
Figure. 3: Component and wiring connections.....	8
Figure. 4: Connections to preamplifier pcb.....	8
Figure. 5: Underside PCB connections.....	9
Tools Required.....	10

## Compilers Note

This manual has been put together and designated Edition 1. The information has been obtained from various sources, including past owners and the Internet; **I cannot vouch for the accuracy of this information.** It is not intended to produce an updated version of this manual, if additional information becomes available it maybe provided as an addendum.

The products produced by Mutek were of high quality and many are still in service. However, please remember that this product came on to the market some 20-30 years ago and must now be regarded as obsolete.

It appears that the successor to this unit is the SLNA290s1 which, hopefully, will be dealt with in its own manual and available if the information required is forthcoming. See History of PCB below.

This manual has no copyright but I would be grateful that if it is used the source is acknowledged. Please let me know if you have further details that would help with this or any other Mutek product.

**\*\*\*\* PLEASE NOTE: \*\*\*\***

The information contained herein is provided in good faith and I will not be responsible for any outcomes arising from the use of it. I have put it together for use by the amateur radio fraternity.

The list of other manuals can be found on my website [www.gm4fzh.co.uk](http://www.gm4fzh.co.uk) (as they become available) where there are also details of how to contact me. I have no association with the firm Mutek and this manual has been produced at my own expense and without any payment.

*Clive Smith, GM4FZH, Spring 2020*

The filename of this document is *preamp slna145sb.pdf*.

## Specification

Noise Figure	1 dB typical
Transducer Gain	0 - 15 dB
Input third order intercept	+2 dBm
Input 1dB compression point	-14 dBm
1dB bandwidth	4 MHz
20dB bandwidth	12 MHz
Relay Handling Power	40W (vswr < 2.0:1)
Relay control voltage	6V dc
Preamp voltage	12V dc
Preamp size	53 x 35 x 15 mm (typical)

## Kit List

Your kit should contain the following items:-

SLNA145sb board	1 off
M3 x 6 Screw	2 off
red coax	1 x 100mm
blue coax	1 x 100mm
white coax	1 x 180mm
red wire	1 x 150mm
orange wire	1 x 150mm
Trimmer tool	1 off

If any of the parts are not present please contact your dealer/ distributor or ourselves directly.

## History of the PCB

After some research, the history of this pcb (in bold) appears to be as follows, EOE.

PCB Type	Notes	Approx. date of issue
*144MHz preamplifier	Very early pcbs. Standard components, hand layout.	1979-1983
<b>SLNA145sb PA00065</b>	<b>Through hole components. Produced as a preamplifier for the FT290 Mk1.</b>	<b>Circa 1983 onwards</b>
*SLNA145s	Stand-alone preamplifier but part could be cut to form a pcb similar to SLNA290s1. Uses SMD	1995
*SLNA290s1	Uses SMD and produced as a preamplifier for the FT290 Mk1.	1995

\* Denotes not covered by this manual.

## Introduction

Thank you for buying Mutek's SLN145sb transceiver optimised preamplifier for your FT290R Mk1. Although they have been designed specifically for this transceiver, they may also find applications in other transceivers for which a complete front end modification is not available. The installation notes below refer to the SLNA145sb, we regret that we cannot provide information for installing the unit in other transceivers.

There are usually two reasons for the less than adequate sensitivity of modern transceivers. Firstly, the receiver designer must balance strong signal handling against sensitivity. With the devices currently available and at the prices the manufacturer is prepared to pay, the balance usually comes out around 4 - 6dB noise figure and a 50 - 70dB dynamic range. The second point is that a typical economy is to use diode switching instead of an electromechanical relay. These diode switches are also usually run at low currents to save battery power and this inevitably leads to a greater insertion loss, often up to 4 dB. Hence it is not unusual for the noise figure to exceed 8dB.

At 144 MHz sky noise limits the maximum useable sensitivity of a receiver used for terrestrial communications to about 2dB noise figure (This corresponds to about 0.05uV for 10dB s+n/n ratio in ssb bandwidths). Lower noise figures can be obtained but will not let you hear any more. However, there is an advantage to using a low noise preamplifier to improve the sensitivity of a transceiver - it reduces the gain required to achieve the desired effect and hence does not degrade the dynamic range as much.

Overall system noise figure depends not only on the noise figure of the preamplifier but also on its gain and the second stage noise figure. By adjusting the gain of the preamplifier, it is possible to set the system noise figure to any value greater than the intrinsic noise figure of the preamplifier-transceiver system. Why adjust the gain? It is an unfortunate fact that the more gain ahead of the receiver, the more susceptible it becomes to overload by strong signals. By putting the minimum amount of low noise gain ahead of the receiver so as to set the sensitivity to a level where external noise is the limiting factor, an optimum (for the system) level is reached. A very low noise amplifier such as the SLNA 290s1 (a later model) will minimise the amount of gain required, and hence minimise the degradation of the dynamics

## Circuit Description

A low loss relay provides the antenna changeover function. This is followed by a BF981 in a noise matched amplifier configuration. This provides the lowest noise figure with the optimum dynamic range. Following the output matching, a variable attenuator provides the gain control facility, without compromising the dynamic performance or the noise figure of the amplifier, as would be the case if the usual practice of varying the gate 2 bias was adopted. Following the attenuator, a bandpass filter provides substantial rejection of out of band signals, preventing these from reaching the original receiver and causing intermodulation. The amplifier has been designed, constructed and tested to very high standards. A plated through hole fibreglass-epoxy pcb is used, and bushed mountings are provided for attachment.

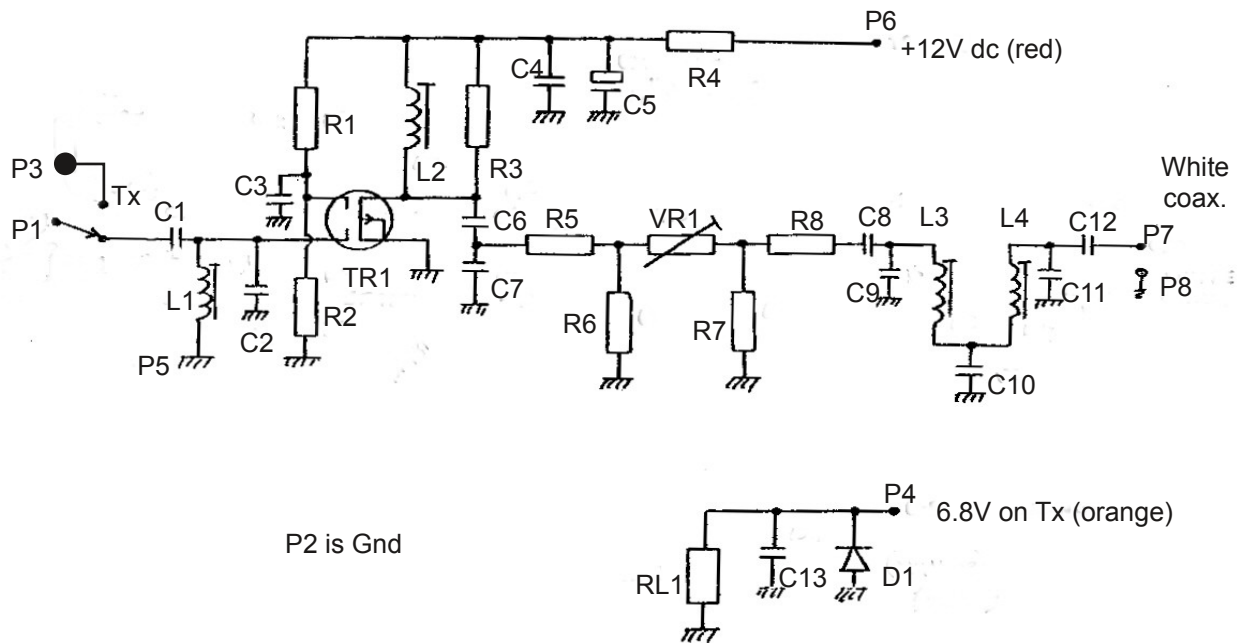

**Figure 1: Circuit Diagram**

Ref	Value	Ref	Value	Ref	Value
R1	82k	C2	1p8	C12	1p8
R2	39k	C3	1n0	C13	10n
R3	39k	C4	1n0		
R4	120R	C5	10u, 16V	L1	Type 100-074
R5	18R	C6	8p2	L2	Type 100-074
R6	68R	C7	22p	L3	Type 100-076
R7	68R	C8	1p8	L4	Type 100-076
R8	18R	C9	1p8	RL1	6V relay
VR1	470R pot.	C10	120p	D1	1N4148
C1	5p6	C11	1p8	TR1	BF981/988

**Table 1: Component Listing**

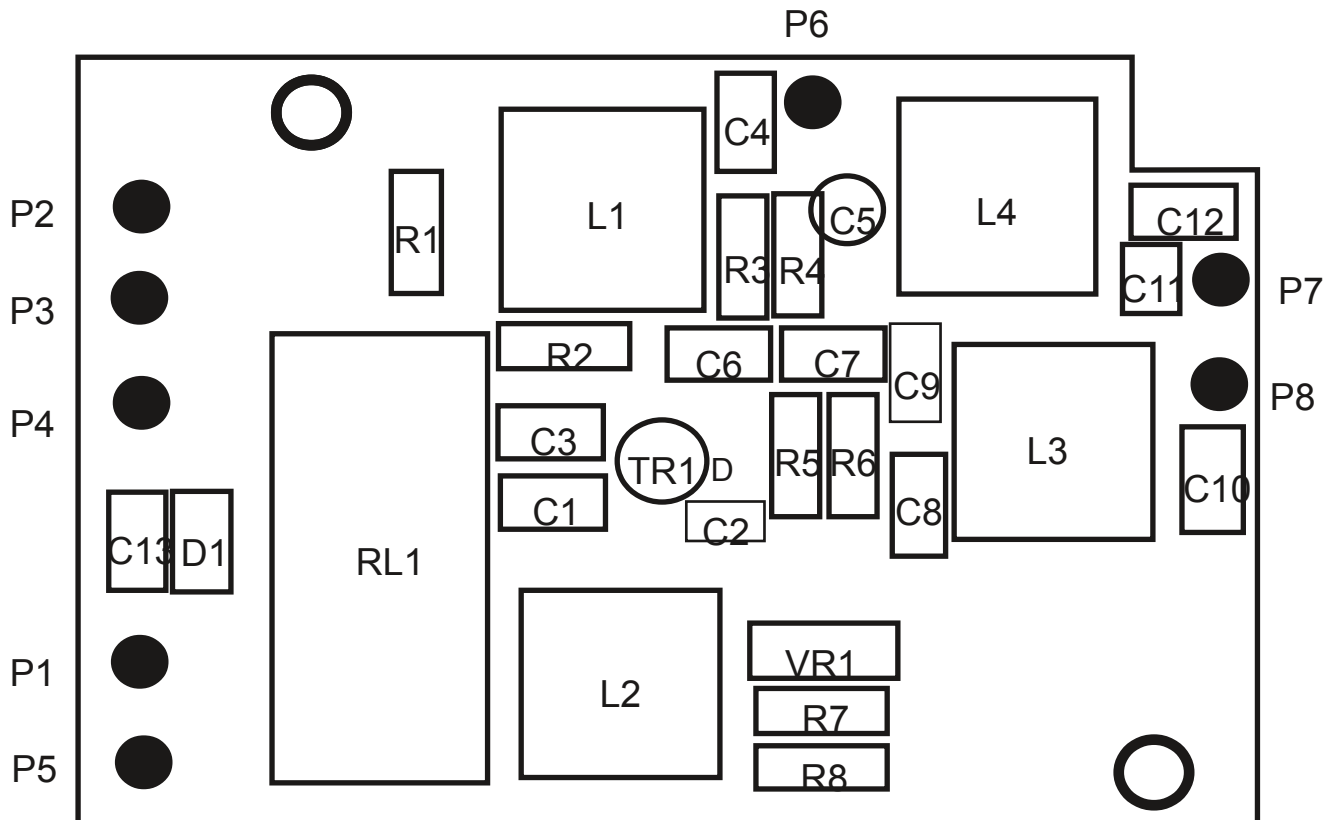

**Figure 2; Component Layout**

## Installation Notes

Before attempting installation of the SLNA145sb it is very strongly recommended that the FT290 manual and circuit diagrams are studied thoroughly. If you are at all uncertain of your abilities we recommend that you find a competent technician to perform the installation; we cannot accept responsibility for any damage however caused. If any difficulties are encountered then please get in touch with us - we want to ensure that you are happy. The preamplifier mounts on the lugs provided for the mounting of the optional tone squelch module. With the bottom of the unit removed these may be found close to the Switch B unit (see page 33 of the FT290 manual), between the battery compartment and the side of the case.

## Detailed Installation

1. Remove the top and bottom covers from the transceiver; top cover has two screws at the back and the bottom cover has a clip. Note: Unsolder the speaker leads to prevent damage.
2. Remove the battery compartment (remove 2 screws, loosen 2 screws).
3. Locate (see Fig .3) and remove C101. This capacitor is located on the main pcb near the PA compartment, close to the back panel of the transceiver. This may be accomplished by crushing the component with a pair of long nosed pliers and then cutting the remaining leads

flush with the board. This may sound a bit crude, but it is better than wrecking the foil pattern on the reverse side of the board.

4. Locate and remove L 02 - this is a yellow sleeved toroidal inductor soldered between the stand-off in the PA compartment and the adjacent tag strip. Retain this component, in the unlikely event of the SLNA145sb having to be returned for service, the FT 290 can easily be returned to its unmodified state by replacing the removed components. C101 may be replaced by any miniature ceramic plate capacitor between 47pf and 1nf.

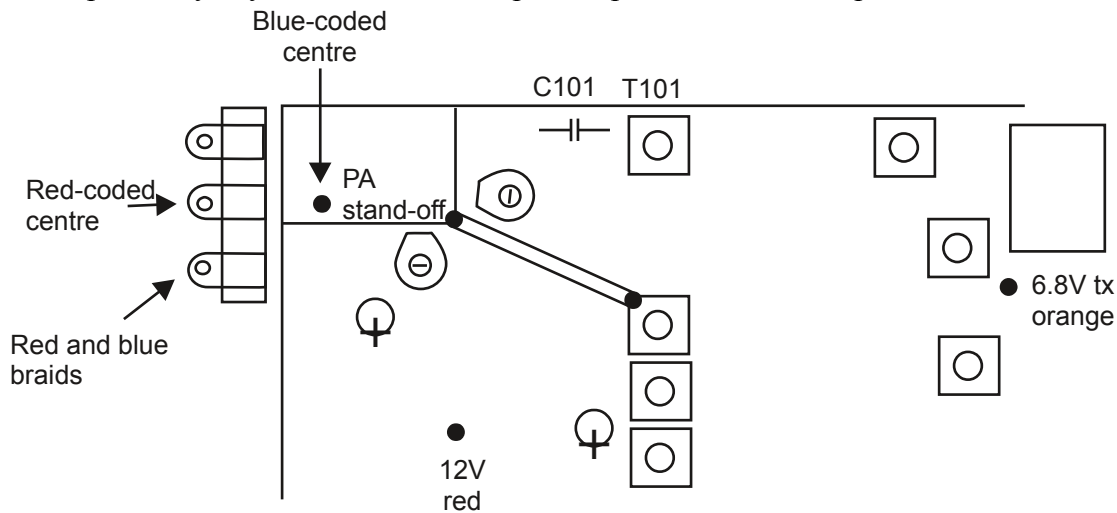

**Figure. 3: Component and wiring connections**

5. Remove the telescopic antenna
6. Remove the anodised aluminium trim from the antenna side of the case.
7. Remove or loosen the screws securing the antenna screening tube and carefully bend the assembly away - thus providing access to the space in which the preamplifier will be mounted.

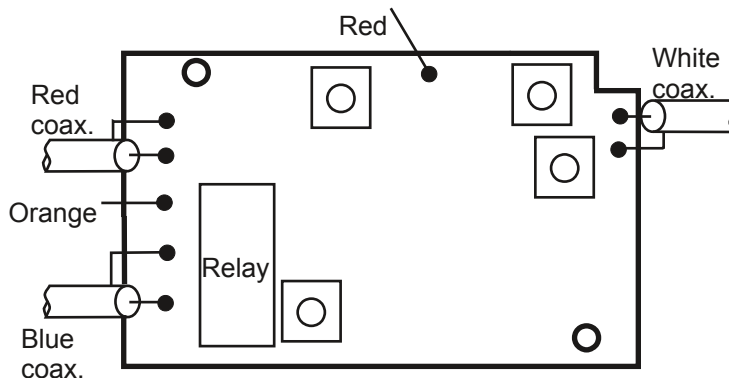
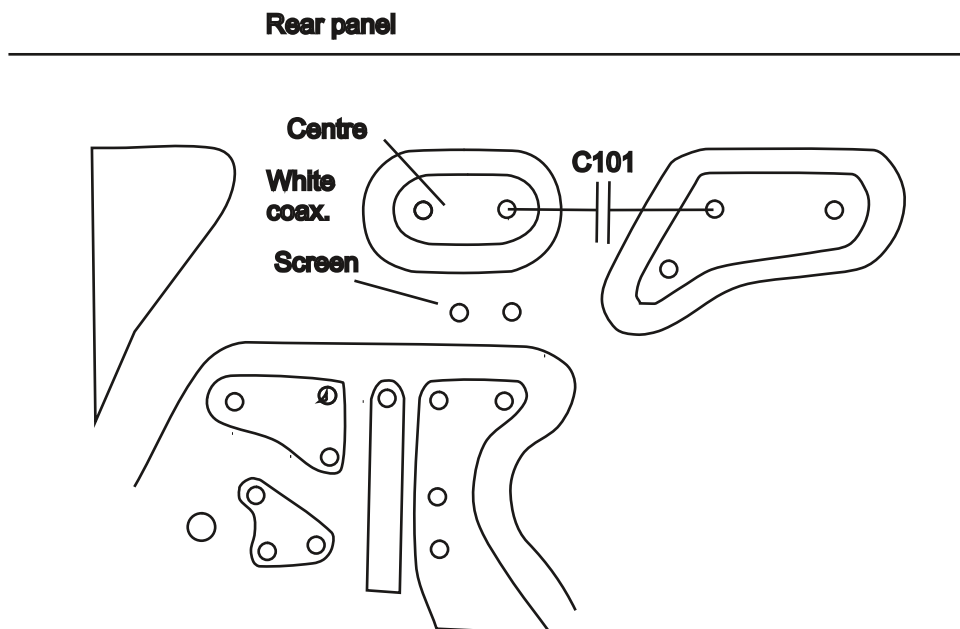

**Figure. 4: Connections to preamplifier pcb**

8. Unwrap the SLNA145sb and the kit of cables. Refer to Fig.4 and solder the cables to the

preamplifier as shown. BE VERY CAREFUL NOT to allow small whiskers of braid from the screened cables to short across the pads.

9. Mount the preamplifier using the M3 screws provided, in the space for the tone squelch unit.
10. Solder the screens of the red and blue coded cables to the earthed tag on the tag strip by the PA compartment. Leave enough slack in all of the connecting cables to allow the preamplifier board to be extended clear of the case.
11. Solder the centre conductor of the blue coded cable to the stand off in the pa compartment form which the inductor L 02 was removed.
12. Solder the centre of the red coded cable to the centre tag of the tag strip.
13. It is possible to do the installation without this step, but it does provide a little more room. Remove the four countersunk screws that secure the back panel of the transceiver and very carefully ease it away from the main pcb. It may be necessary to unsolder the wide metal tape between the pcb ground and the ground of the SO239 RF connector.
14. Locate the transformer T101 (T01 in some manuals). This is the shiny metal can next to where C101 used to be. Now look at the track side of the board under T101 - see Fig.5. You should recognise the diagram as representing the copper foil pattern. Solder the centre of the white coded cable to the copper pad and the screen of the cable to the adjacent ground area. This is probably the most fiddly operation so take great care not to allow whiskers of braid to short anything out.



**Figure. 5: Underside PCB connections**

15. After double checking the previous operation, replace the back plate of the transceiver with the 4 countersunk screws.
16. Solder the red wire to the 12V stand-off on the main pcb as shown on Fig.3.
17. Solder the orange wire to the 6.8V Tx stand off as shown on Fig.3.
18. Replace the antenna screening tube
19. Replace the anodised aluminium trim
20. Replace the battery compartment, taking care not to trap the red wire – shorted nicads create a fire risk!
21. Either plug in an external speaker or reconnect the internal speaker. Connect a power supply and an antenna to the transceiver. Turn on and find a weak signal using FM mode. Now adjust the attenuator on the preamplifier board using the trimmer tool provided until the slightest degradation in signal to noise ratio is noticed, then back-off this adjustment very slightly. This procedure will ensure the maximum dynamic range for the system is achieved.
22. Replace the top and bottom covers. Installation is now complete.

## Tools Required

Soldering Iron (small)  
Side cutters

Solder (thin multicore)  
Small pair of pliers (long nose)

Solder sucker (might be useful)  
Screwdriver